

- NOTES:**
- BEARING SYSTEM SHOWN HEREON IS BASED ON GRID NORTH AS ESTABLISHED FROM CITY OF BRYAN G.P.S. MONUMENTS.
 - THIS PROPERTY IS CURRENTLY ZONED PLANNED DEVELOPMENT-MIXED USE (PD-M).
 - IRON RODS WILL BE SET AT ALL LOT CORNERS AND ANGLE POINTS UNLESS OTHERWISE NOTED.
 - A PORTION OF THIS TRACT IS WITHIN A DESIGNATED 100 YEAR FLOOD PLAIN ACCORDING TO THE F.I.R.M. MAPS, COMMUNITY PANEL NO. 4504100142 C, REVISED TO REFLECT THE L.O.M.R. DATED JANUARY 11, 2004.
 - BUILDING SETBACK LINES TO BE IN ACCORDANCE WITH THE CITY OF BRYAN SITE DEVELOPMENT REVIEW ORDINANCE FOR PATIO HOMES. ZERO LOT LINE CONSTRUCTION IS PROPOSED FOR THE RESIDENTIAL STRUCTURES IN THIS SUBDIVISION.
 - CURVE LENGTHS SHOWN ALONG THE BOUNDARY OR RIGHT-OF-WAY LINES ARE ARC LENGTHS.
 - MAINTENANCE OF THE COMMON AREAS (INCLUDING STREET MEDIAN ISLANDS) WILL BE BY THE PARK VILLAGE HOMEOWNERS ASSOCIATION. LANDSCAPING OR OTHER AMENITIES PROPOSED WITHIN THE STREET MEDIAN ISLANDS OR PUBLIC UTILITY EASEMENTS SHALL BE APPROVED BY THE CITY OF BRYAN.
 - THE COMMON AREAS WILL BE OWNED BY THE PARK VILLAGE HOMEOWNERS ASSOCIATION.
 - THE OWNER OF THIS PROPERTY IS BRYAN DEVELOPMENT, LTD., P.O. BOX 3462, BRYAN, TEXAS, 77805.
 - IN ADDITION TO THE REQUIREMENT THAT THE FINISH FLOOR BE CONSTRUCTED A MINIMUM OF TWO FEET ABOVE THE BFE (BASE FLOOD ELEVATION), A DEVELOPMENT PERMIT AND AN ELEVATION CERTIFICATE WILL ALSO BE REQUIRED FOR LOTS 9, 10 AND 13 THRU 19 OF BLOCK 1, AND LOTS 1 THRU 13 OF BLOCK 2.
 - THE MINIMUM LOT SIZE WILL BE 5,500 SQUARE FEET. THE MINIMUM LOT WIDTH WILL BE 31 FEET AT THE RIGHT-OF-WAY LINE OR THE REAR LOT LINE. THE MINIMUM LOT DEPTH WILL BE 90 FEET. THE MINIMUM LOT WIDTH AT THE FRONT AND REAR SETBACK LINES WILL BE 45 FEET.
 - ADDITIONAL EASEMENTS WILL NEED TO BE GIVEN THROUGH THE COMMON AREA BY SEPARATE INSTRUMENT ONCE FINAL POLE AND TRANSFORMER LOCATIONS HAVE BEEN ESTABLISHED.

Doc 00904042 Bk OR Vol 6925 Pg 85
 Filed for Record in: BRAZOS COUNTY
 On: Sep 13, 2005 at 10:49A
 As a Plat
 Document Number: 00904042
 Amount: 56.00
 Receipt Number - 275022
 By: Jaime Hines

STATE OF TEXAS
 I hereby certify that this instrument was filed on the date and time stamped herein by me and was duly recorded in the volume and page of the map records of BRAZOS COUNTY as stamped herein by me.
 Sep 13, 2005
 HONORABLE WENDELL WALKER, COUNTY CLERK
 BRAZOS COUNTY

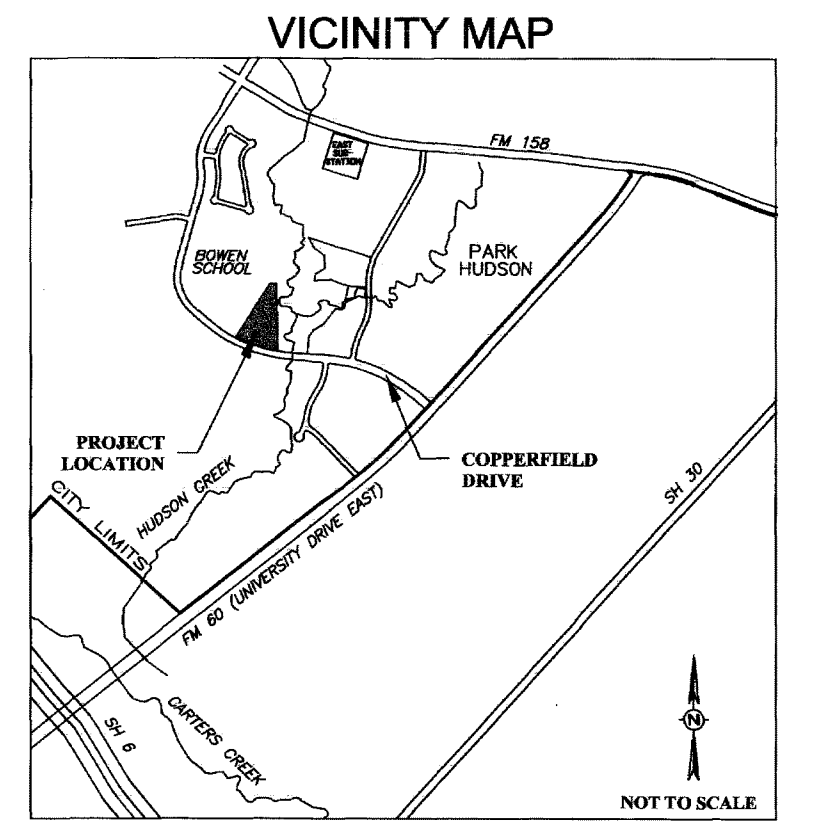

METES AND BOUNDS DESCRIPTION OF ALL THAT CERTAIN TRACT OR PARCEL OF LAND LYING AND BEING SITUATED IN THE J. W. SCOTT SURVEY, ABSTRACT NO. 49, AND THE RICHARD CARTER SURVEY, ABSTRACT NO. 8, BRYAN, BRAZOS COUNTY, TEXAS, SAID TRACT BEING A PORTION OF THE REMAINDER OF A CALLED 351.933 ACRE TRACT AS DESCRIBED BY A DEED TO BRYAN DEVELOPMENT, LTD., RECORDED IN VOLUME 3734, PAGE 105 OF THE OFFICIAL PUBLIC RECORDS OF BRAZOS COUNTY, TEXAS, AND ALL OF A CALLED 0.057 ACRE TRACT DESCRIBED ON PAGE 8 OF EXHIBIT "A" BY A DEED TO BRYAN DEVELOPMENT, LTD., RECORDED IN VOLUME 3375, PAGE 144 OF THE OFFICIAL PUBLIC RECORDS OF BRAZOS COUNTY, TEXAS.

SAID TRACT BEING MORE PARTICULARLY DESCRIBED BY METES AND BOUNDS AS FOLLOWS:
 BEGINNING AT A 1/2 INCH IRON ROD FOUND ON THE NORTHEAST LINE OF COPPERFIELD DRIVE (80' R.O.W.) MARKING THE SOUTH CORNER OF LOT 1, BLOCK 1, TIFFANY PARK SUBDIVISION, PHASE ONE, ACCORDING TO THE PLAT RECORDED IN VOLUME 2146, PAGE 160 OF THE OFFICIAL PUBLIC RECORDS OF BRAZOS COUNTY, TEXAS, AND THE WEST CORNER OF SAID 0.057 ACRE TRACT;
 THENCE: N 42° 03' 11" E ALONG THE SOUTHWEST LINE OF SAID LOT 1 FOR A DISTANCE OF 1065.41 FEET TO A 1/2 INCH IRON ROD FOUND MARKING AN ANGLE POINT IN SAID LINE AND A NORTHWEST CORNER OF A CALLED 71.543 ACRE TRACT DESCRIBED AS TRACT TWO BY A DEED TO THE BOARD OF DIRECTORS OF BRYAN REINVESTMENT ZONE NUMBER EIGHT RECORDED IN VOLUME 3847, PAGE 162 OF THE OFFICIAL PUBLIC RECORDS OF BRAZOS COUNTY, TEXAS (THIS LINE WAS USED FOR BEARING ORIENTATION HONORING THE DEED CALL BEARING OF SAID 351.933 ACRE TRACT, 3734/105);

THENCE: S 74° 41' 24" E ALONG A SOUTHWEST LINE OF SAID 71.543 ACRE TRACT FOR A DISTANCE OF 117.58 FEET TO A 1/2 INCH IRON ROD FOUND MARKING AN INTERIOR WEST CORNER OF SAID 71.543 ACRE TRACT;
 THENCE: S 08° 43' 03" W ALONG A WESTERLY LINE OF SAID 71.543 ACRE TRACT FOR A DISTANCE OF 1146.08 FEET TO A 1/2 INCH IRON ROD FOUND ON THE NORTHEAST LINE OF COPPERFIELD DRIVE MARKING THE SOUTHWEST CORNER OF SAID 71.543 ACRE TRACT, SAID IRON ROD FOUND BEING IN A CLOCKWISE CURVE HAVING A RADIUS OF 1760.00 FEET;
 THENCE: ALONG SAID CURVE THROUGH A CENTRAL ANGLE OF 24° 40' 41" FOR AN ARC DISTANCE OF 758.05 FEET (CHORD BEARS: N 60° 17' 25" W - 752.21 FEET) TO THE POINT OF BEGINNING CONTAINING 10.992 ACRES OF LAND AS SURVEYED ON THE GROUND OCTOBER, 2004. SEE PLAT PREPARED NOVEMBER, 2004, FOR MORE DESCRIPTIVE INFORMATION.

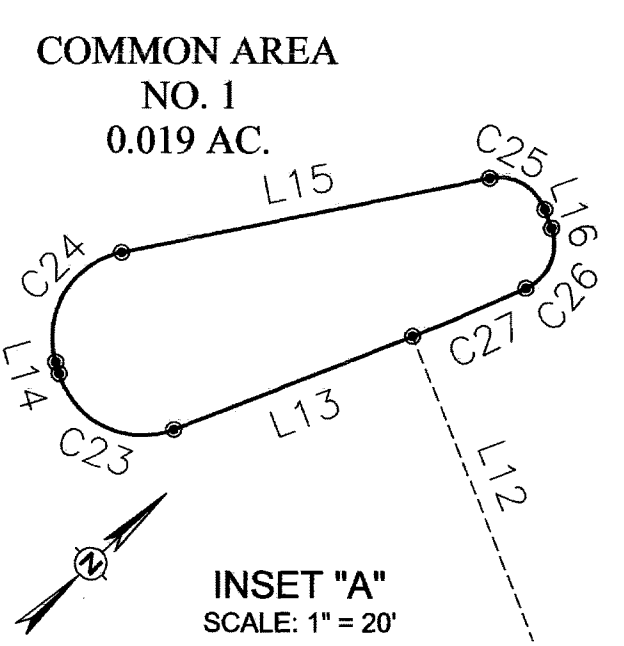

CURVE TABLE

CURVE	LENGTH	RADIUS	DELTA	TANGENT	CHORD	CHORD BEARING
C1	758.05'	1760.00'	24°40'41"	385.00'	752.21'	N60°17'25"W
C2	38.06'	25.00'	87°14'18"	23.82'	34.46'	N75°09'34"W
C3	115.98'	225.00'	28°32'04"	59.31'	114.20'	N16°48'23"E
C4	39.27'	25.00'	90°00'00"	25.00'	35.36'	N42°59'39"W
C5	21.98'	225.00'	5°35'46"	11.00'	21.97'	N85°11'46"W
C6	218.63'	50.00'	250°31'44"	70.71'	81.65'	N42°51'59"E
C7	30.77'	25.00'	70°31'44"	17.68'	28.87'	S47°08'01"E
C8	17.09'	175.00'	5°35'46"	8.55'	17.09'	S85°11'46"E
C9	39.27'	25.00'	90°00'00"	25.00'	35.36'	N47°09'34"W
C10	18.23'	275.00'	32°25'11"	8.12'	18.22'	N03°41'47"E
C11	26.04'	25.00'	59°40'07"	14.34'	24.87'	N24°26'51"W
C12	128.35'	50.00'	147°04'53"	169.24'	95.90'	N19°15'32"E
C13	26.04'	25.00'	59°40'07"	14.34'	24.87'	N62°57'55"E
C14	42.82'	275.00'	8°55'20"	21.45'	42.78'	N37°35'31"E
C15	218.63'	50.00'	250°31'44"	70.71'	81.65'	S12°40'57"E
C16	30.77'	25.00'	70°31'44"	17.68'	28.87'	S77°19'03"W
C17	157.27'	225.00'	40°02'50"	82.00'	154.08'	S22°01'46"W
C18	93.76'	275.00'	19°32'04"	47.34'	93.31'	S11°46'23"W
C19	38.07'	25.00'	87°14'48"	23.83'	34.50'	S22°04'59"E
C20	230.87'	1735.00'	7°37'26"	115.60'	230.70'	S68°41'30"E
C21	352.61'	1735.00'	11°38'40"	176.91'	352.00'	S56°13'34"E
C22	14.92'	9.00'	95°00'00"	9.82'	13.27'	S89°02'25"W
C23	14.92'	9.00'	95°00'00"	9.82'	13.27'	N15°57'35"W
C24	7.14'	5.00'	81°48'24"	4.33'	7.14'	N22°26'37"E
C25	7.43'	5.00'	85°09'43"	4.59'	6.77'	S24°04'19"E
C26	12.75'	241.00'	3°01'53"	6.38'	12.75'	S20°01'29"W
C27	34.27'	1735.00'	1°07'55"	17.14'	34.27'	S49°50'17"E
C28	34.27'	1735.00'	1°07'55"	17.14'	34.27'	S49°50'17"E

NOTE: C2 HAS BEEN OMITTED.

LINE TABLE

LINE	LENGTH	BEARING
L4	44.38'	N31°32'25"E
L5	20.22'	N02°00'21"E
L6	42.67'	N87°59'39"W
L7	92.77'	N82°23'53"W
L8	22.06'	S82°23'53"E
L9	42.67'	S87°59'39"E
L10	21.16'	S21°32'25"W
L11	21.70'	N24°50'51"E
L12	34.00'	N68°27'35"W
L13	26.60'	S21°32'25"W
L14	1.24'	N63°27'35"W
L15	38.93'	N31°32'25"E
L16	2.09'	S66°39'11"E
L17	50.00'	N02°36'07"E
L18	50.00'	N22°34'55"E
L19	25.00'	S39°36'00"W
L20	28.03'	S03°26'33"E
L21	20.00'	N47°56'49"W

NOTE: L1, L2 & L3 HAVE BEEN OMITTED.

BOARD OF DIRECTORS OF BRYAN REINVESTMENT ZONE NUMBER EIGHT
 TRACT TWO, 3847/162

CERTIFICATE OF OWNERSHIP AND DEDICATION
 STATE OF TEXAS
 COUNTY OF BRAZOS

I, William J. Lero, President of Bryan Development, Ltd., a Texas Limited Partnership, By Bryan Development General Partner, Inc., General Partner, owner and developer of the 10.992 acre tract shown on this plat, being part of the tract of land conveyed in the Deed Records of Brazos County in Volume 3734, Page 105, and Volume 3375, Page 144, and designated herein as the Park Village Subdivision, in the City of Bryan, Texas and whose name is subscribed hereto, hereby dedicate to the use of the public forever all streets, alleys, parks, easements and public places therein shown for the purpose and consideration therein expressed.

William J. Lero
 William J. Lero, President
 Bryan Development, Ltd.

STATE OF TEXAS
 COUNTY OF BRAZOS

Before me, the undersigned authority, on this day personally appeared William J. Lero known to me to be the person whose name is subscribed to the foregoing instrument, and acknowledged to me that he executed the same for the purpose and consideration therein stated.

Given under my hand and seal on this 25th day of August, 2005.

GINGER L. URSO
 Notary Public, State of Texas
 My Commission Expires September 05, 2007

CERTIFICATE OF THE COUNTY CLERK
 STATE OF TEXAS
 COUNTY OF BRAZOS

I, Brad Kerr, Registered Public Surveyor No. 4502, in the State of Texas, hereby certify that this plat is true and correct and was prepared from an actual survey of the property and that the property markers and monuments were placed under my supervision on the ground, and that the metes and bounds describing said subdivision will describe a closed geometric form.

WITNESS my hand and official seal, at my office in Bryan, Texas.

Karen McQueen
 County Clerk
 Brazos County, Texas

CERTIFICATE OF THE SURVEYOR
 STATE OF TEXAS
 COUNTY OF BRAZOS

I, Brad Kerr, Registered Public Surveyor No. 4502, in the State of Texas, hereby certify that this plat is true and correct and was prepared from an actual survey of the property and that the property markers and monuments were placed under my supervision on the ground, and that the metes and bounds describing said subdivision will describe a closed geometric form.

Brad Kerr
 Brad Kerr, R.P.L.S. No. 4502

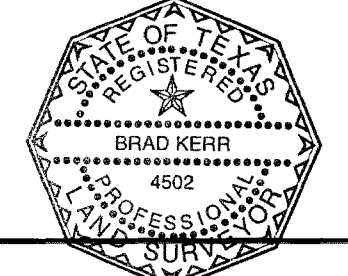

APPROVAL OF PLANNING AND ZONING COMMISSION
 I, *Kim Casey*, Chairman of the Planning and Zoning Commission of the City of Bryan, State of Texas, hereby certify that the attached plat was duly filed for approval with the Planning and Zoning Commission of the City of Bryan on the 28th day of September, 2005, and same was duly approved on the 16th day of December, 2005, by said Commission.

Kim Casey
 Chairman, Planning & Zoning Commission
 Bryan, Texas

APPROVAL OF THE PLANNING ADMINISTRATOR
 I, the undersigned, Planning Administrator and/or designated Secretary of the Planning and Zoning Commission of the City of Bryan, hereby certify that this plat is in compliance with the appropriate codes and ordinances of the City of Bryan and was approved on the 12th day of September, 2005.

Karen Russell
 Planning Administrator, Bryan, Texas

APPROVAL OF THE CITY ENGINEER
 I, the undersigned, City Engineer of the City of Bryan, hereby certify that this plat is in compliance with the appropriate codes and ordinances of the City of Bryan and was approved on the 14th day of September, 2005.

Bill Hill
 City Engineer, Bryan, Texas